

ATL LOGISTICS CENTRE

亞洲貨櫃物流中心



Direct access to container Terminal 3
甲級倉儲設施 緊接3號貨櫃碼頭

KEY PROPERTY FEATURES:

High clearance warehouse space of 17.5 ft to 25 ft
倉庫樓底高度達17.5呎至25呎

With ample ancillary offices available
提供充裕的辦公室配套

Flexible floor plates can accommodate requirements from 16,000 sq ft to 400,000 sq ft
樓面佈局靈活，可迎合16,000平方呎至400,000平方呎的不同單位面積要求

Convenient access to the ports and Hong Kong International Airport for domestic distribution
位置優越，方便往來各碼頭和香港國際機場，有利於本地運輸



1MIN

walk to Container Terminal 3
步行至3號貨櫃碼頭



24MIN

drive to HK International Airport
行車至香港國際機場



10MIN

walk to Lai King MTR
步行至荔景港鐵站



36MIN

drive to Man Kam To
行車至文錦渡



MAKING SPACE FOR GREATNESS

KWAI CHUNG 葵涌

BERTH 3, KWAI CHUNG CONTAINER TERMINAL

3號貨櫃碼頭

PLANS

規劃

5,994,700 SQ FT

平方呎

Total Gross Area (sq ft)
總建築面積 (平方呎)

Floor plate (sq ft)
每層樓面面積 (平方呎)

155,800 - 211,400

Ceiling height (ft/m)
樓高 (呎/米)

17.5-25/5.33-7.62

Floor loading capacity (lbs/sq ft)
樓面負重量 (磅 / 平方呎)

350-450

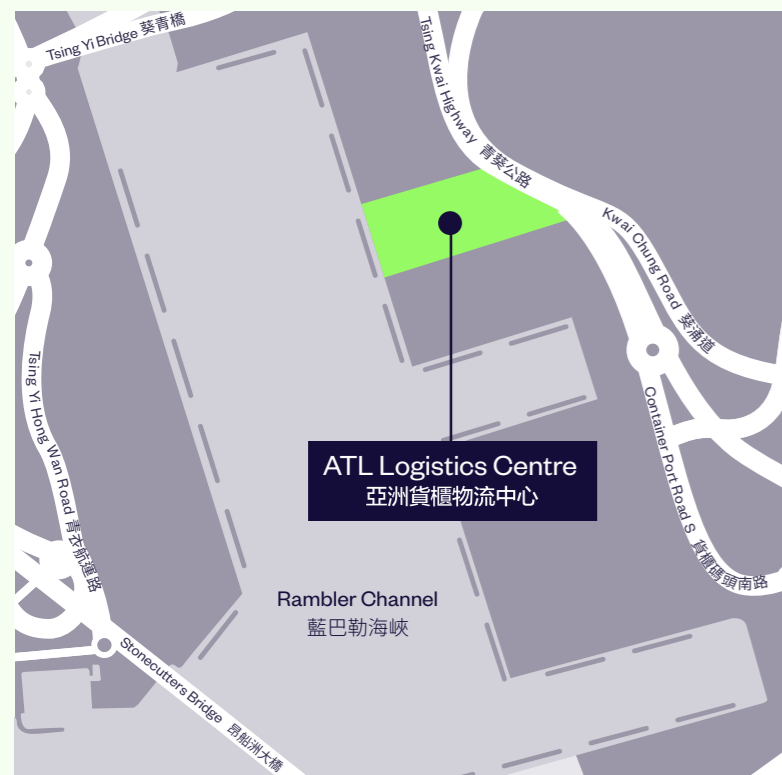

Typical floor plan 平面圖

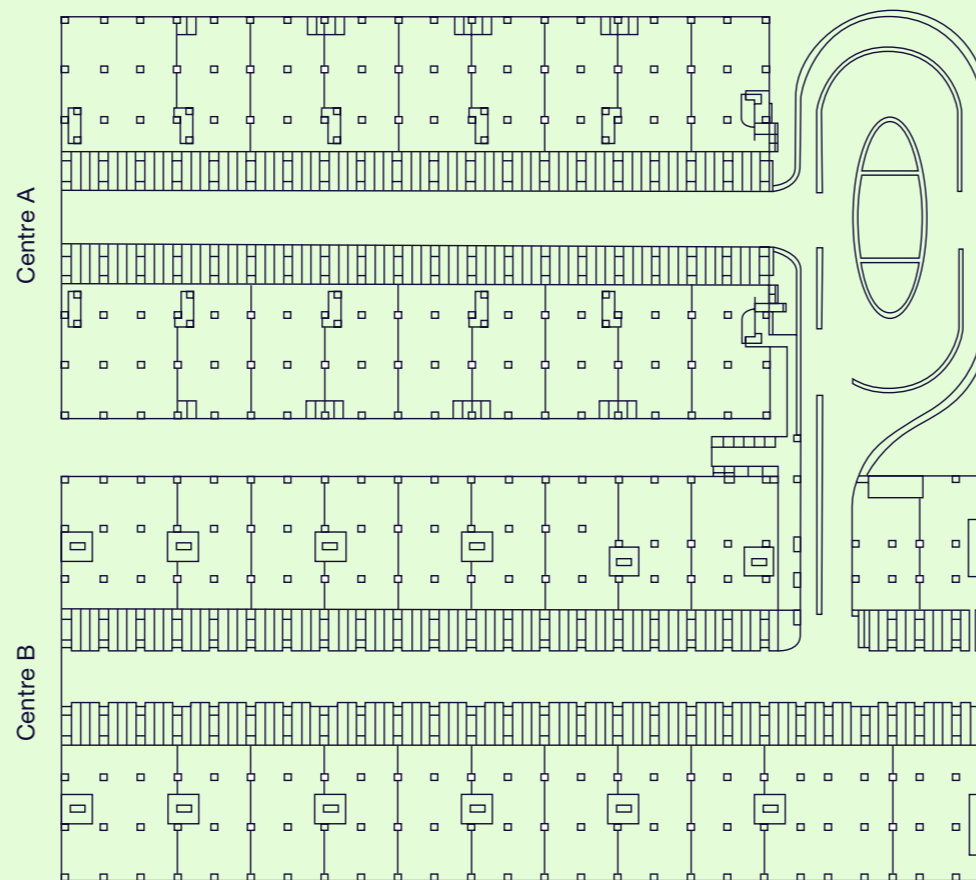
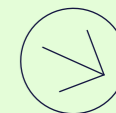

Floors 1 to 6 (excluding Floor 6 Centre B)

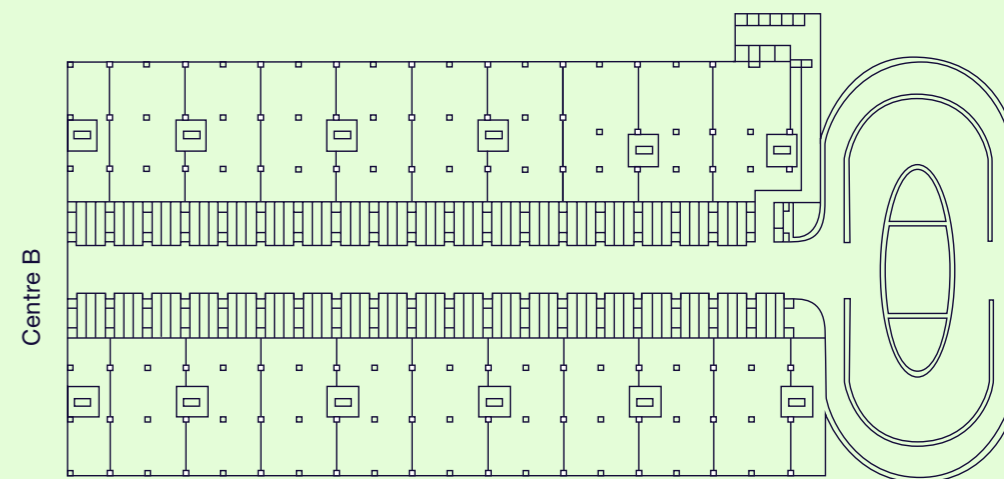

Floors 6, 8 to 11

Disclaimer 免責聲明:

This document has been prepared by Goodman Asia Limited for general information purposes only. Whilst every care has been taken in relation to its accuracy, no warranty of accuracy is given or implied. Interested parties should obtain independent advice before making any decisions about the property referred to in this document. Images contained in this document have been used to enable the visualisation of the building concepts only.

本文件由Goodman Asia Limited (“Goodman”)製作，內容僅供作一般參考之用。Goodman已竭力確保文件所提供之資料準確，但對於資料之準確度，Goodman並不作任何承諾或保證。對本文件所提及之物業有興趣之人士，須自行尋求獨立專業人士提供意見。而本文件所刊載之圖片，只供作瞭解物業概念之用。

goodman.com/hk

